

SECTION B-B

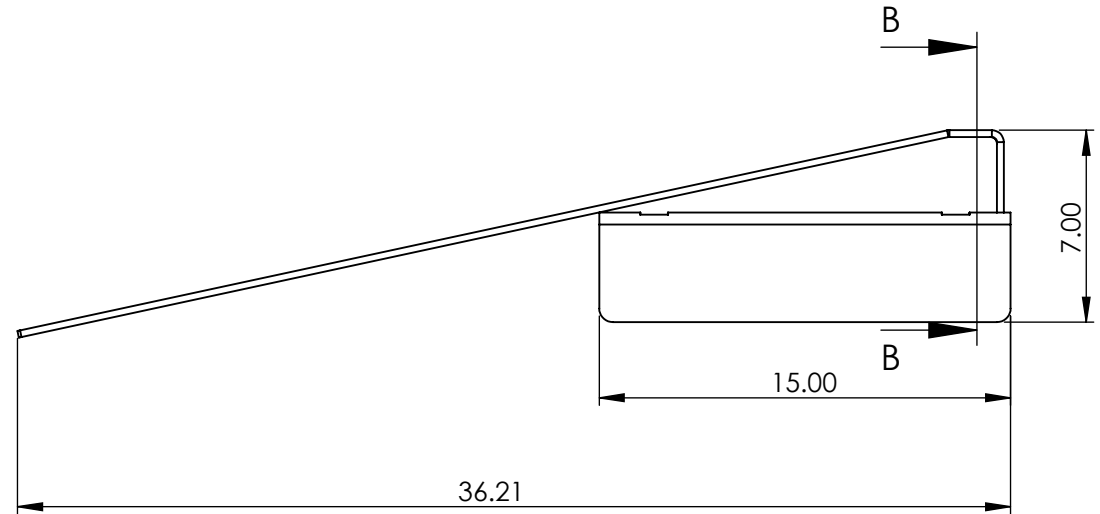

"ALL MATERIAL IS 1/4" THICK, AND IS BOX DESIGNED FOR STRENGTH".

TRIM EXCESS

HEAT AND BEND TO MATCH FRAME ANGLE

DRILL AND BOLT TO MATCH NEW OR EXISTING HOLES IN FRAME

DRILL FOR (3) 1/2" BOLTS MINIMUM

\*\*SOLD IN SETS: 1 LEFT SIDE & 1 RIGHT SIDE\*\*

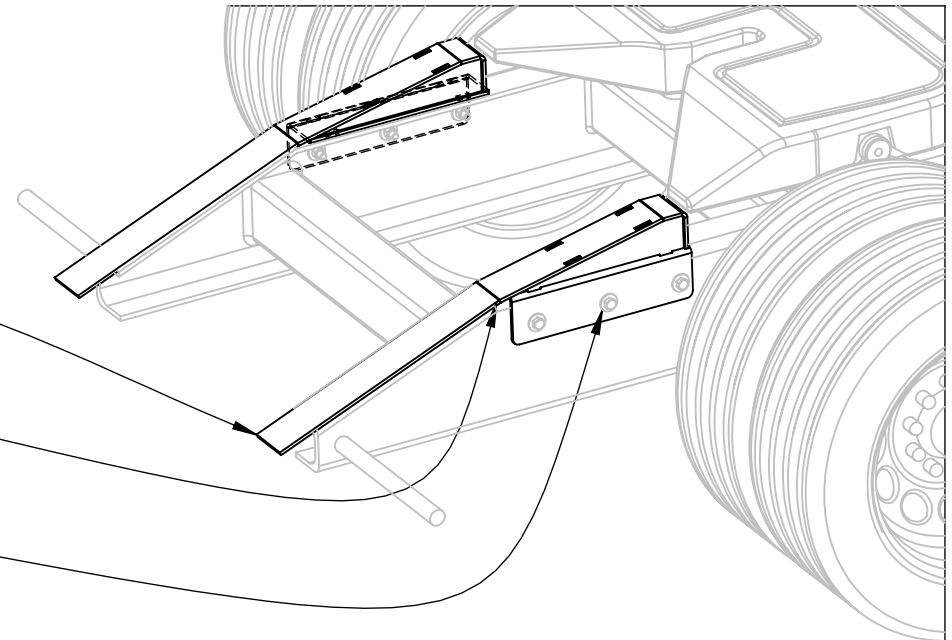

Part No.:

**1954**

MATERIAL: 44W

Approx. Weight: 20.30 lbs

Surf. Area: 4.38 sq. ft.

THICKNESS: 0.250

ICONIC ELEMENTS

PROPRIETARY AND CONFIDENTIAL  
NO PART OF THIS DOCUMENT MAY BE REPRODUCED, STORED IN A RETRIEVAL SYSTEM, OR TRANSMITTED IN ANY FORM, WITHOUT THE WRITTEN PERMISSION OF Iconic Elements Inc.

FINISH: HRAP

TITLE:

3" 5th Wheel Ramp

DWG. NO.: 1611-3-00-C

REV: SHEET:

C 1 OF 2

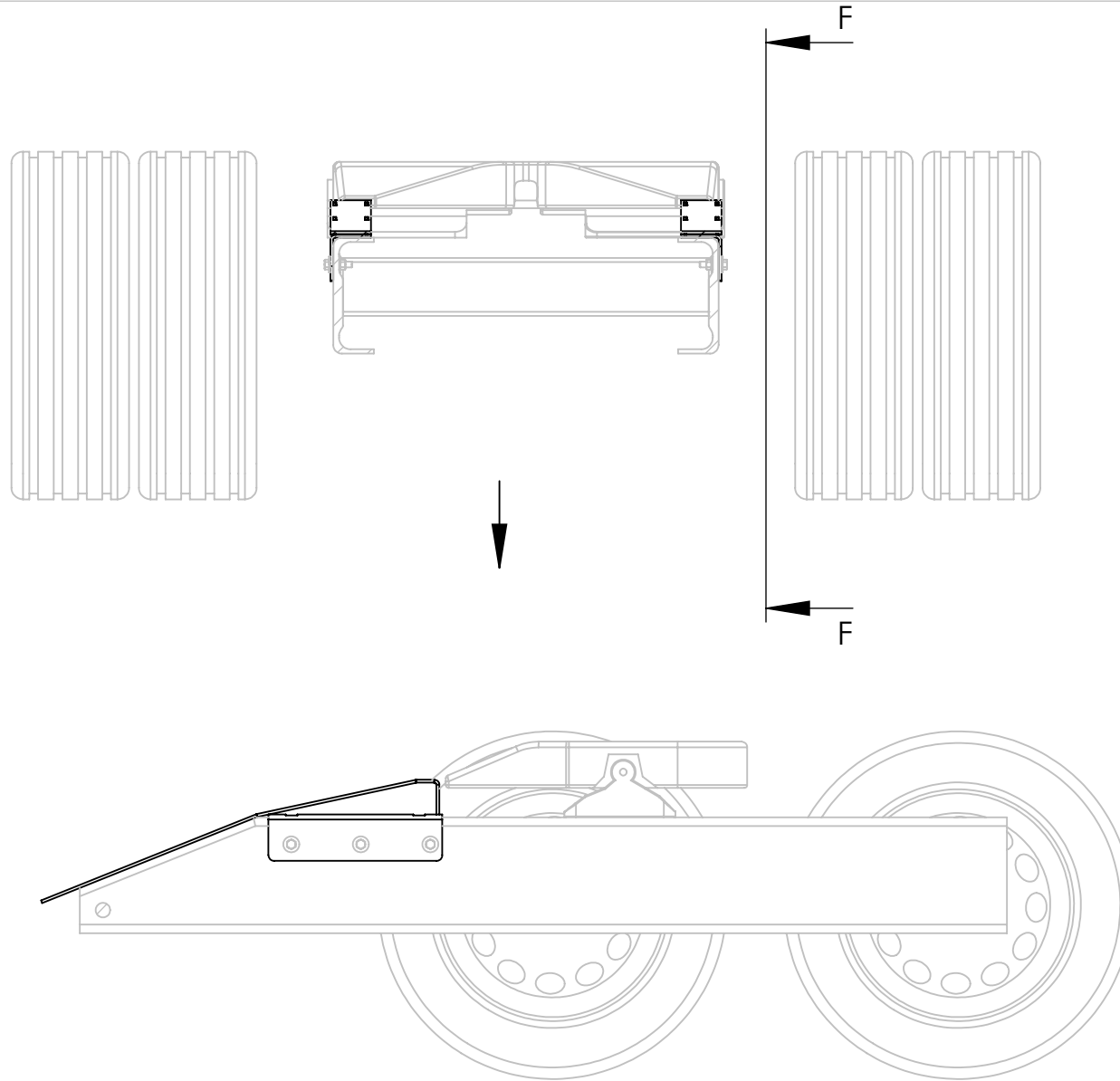

SECTION F-F

Part No.:

**1954**

MATERIAL: 44W

Approx. Weight: 20.30 lbs

Surf. Area: 4.38 sq. ft.

THICKNESS: 0.250

ICONIC ELEMENTS

PROPRIETARY AND CONFIDENTIAL  
NO PART OF THIS DOCUMENT MAY BE REPRODUCED, STORED IN A RETRIEVAL SYSTEM, OR TRANSMITTED IN ANY FORM, WITHOUT THE WRITTEN PERMISSION OF Iconic Elements Inc.

FINISH: HRAP

TITLE:

3" 5th Wheel Ramp

DWG. NO.: 1611-3-00-C

REV: SHEET:

C 2 OF 2

5

4

3

2

1

D

C

B

A