

SECTION B-B

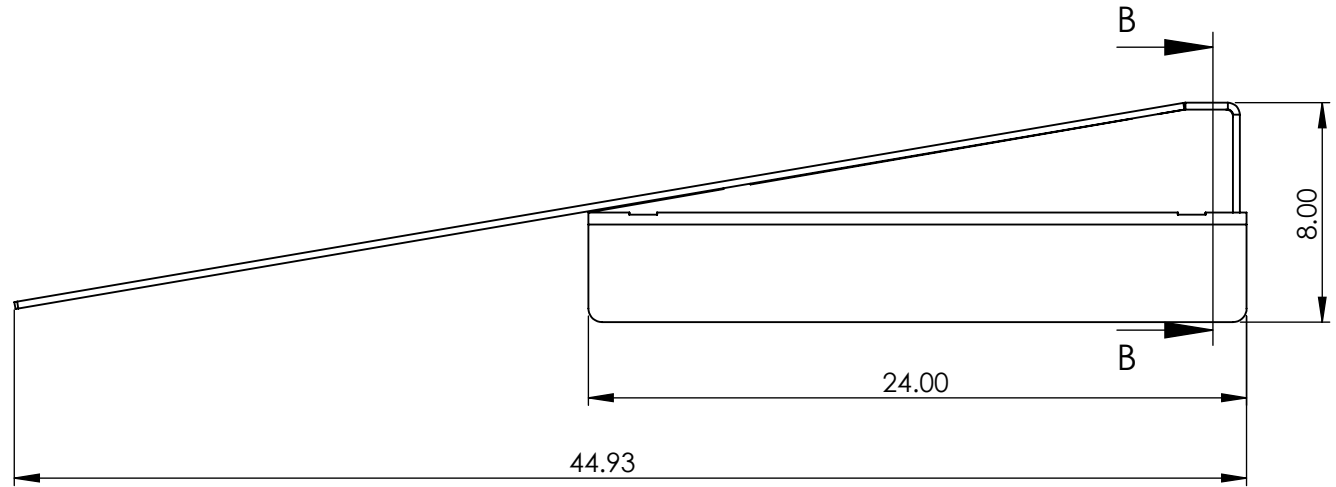

"ALL MATERIAL IS 1/4" THICK, AND IS BOX DESIGNED FOR STRENGTH".

- TRIM EXCESS
- HEAT AND BEND TO MATCH FRAME ANGLE
- DRILL AND BOLT TO MATCH NEW OR EXISTING HOLES IN FRAME
- DRILL FOR (4) 1/2" BOLTS MINIMUM

****SOLD IN SETS: 1 LEFT SIDE & 1 RIGHT SIDE****

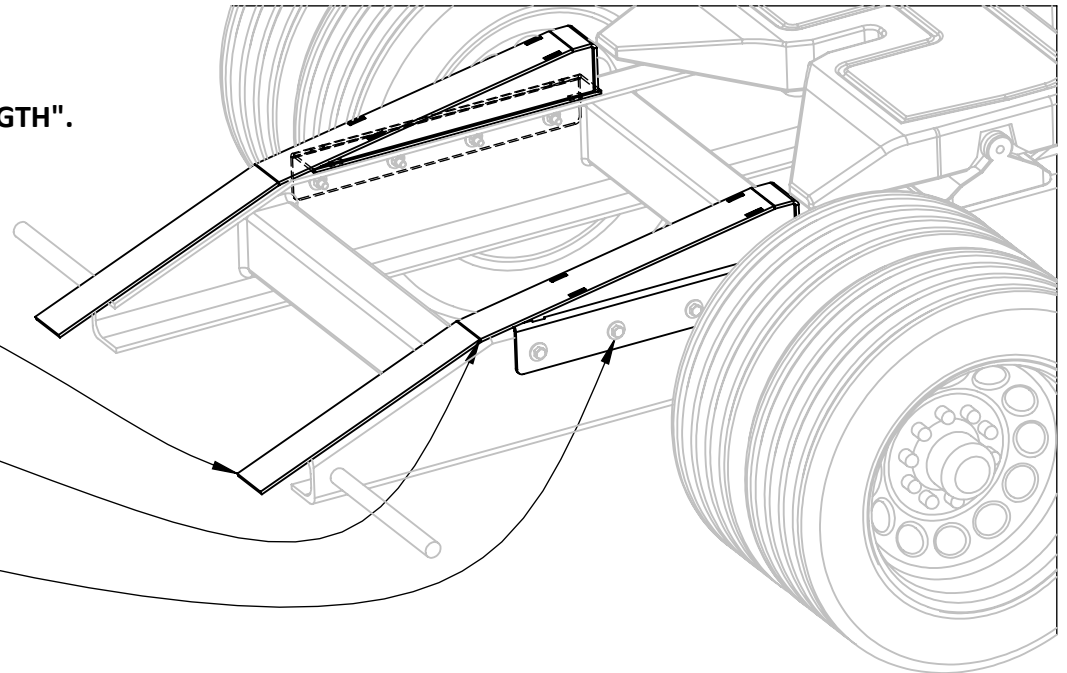

Part No.:	MATERIAL: 44W	THICKNESS: 0.250	FINISH: HRAP	DWG. NO.: 0845-4-00-G
1951	Approx. Weight: 30.69 lbs	ICONIC ELEMENTS		REV: SHEET:
	Surf. Area: 6.56 sq. ft.	NO PART OF THIS DOCUMENT MAY BE REPRODUCED, STORED IN A RETRIEVAL SYSTEM, OR TRANSMITTED IN ANY FORM, WITHOUT THE WRITTEN PERMISSION OF Iconic Elements Inc.		G 1 OF 2
		TITLE: 4" 5th Wheel Ramp		

5

4

3

2

1

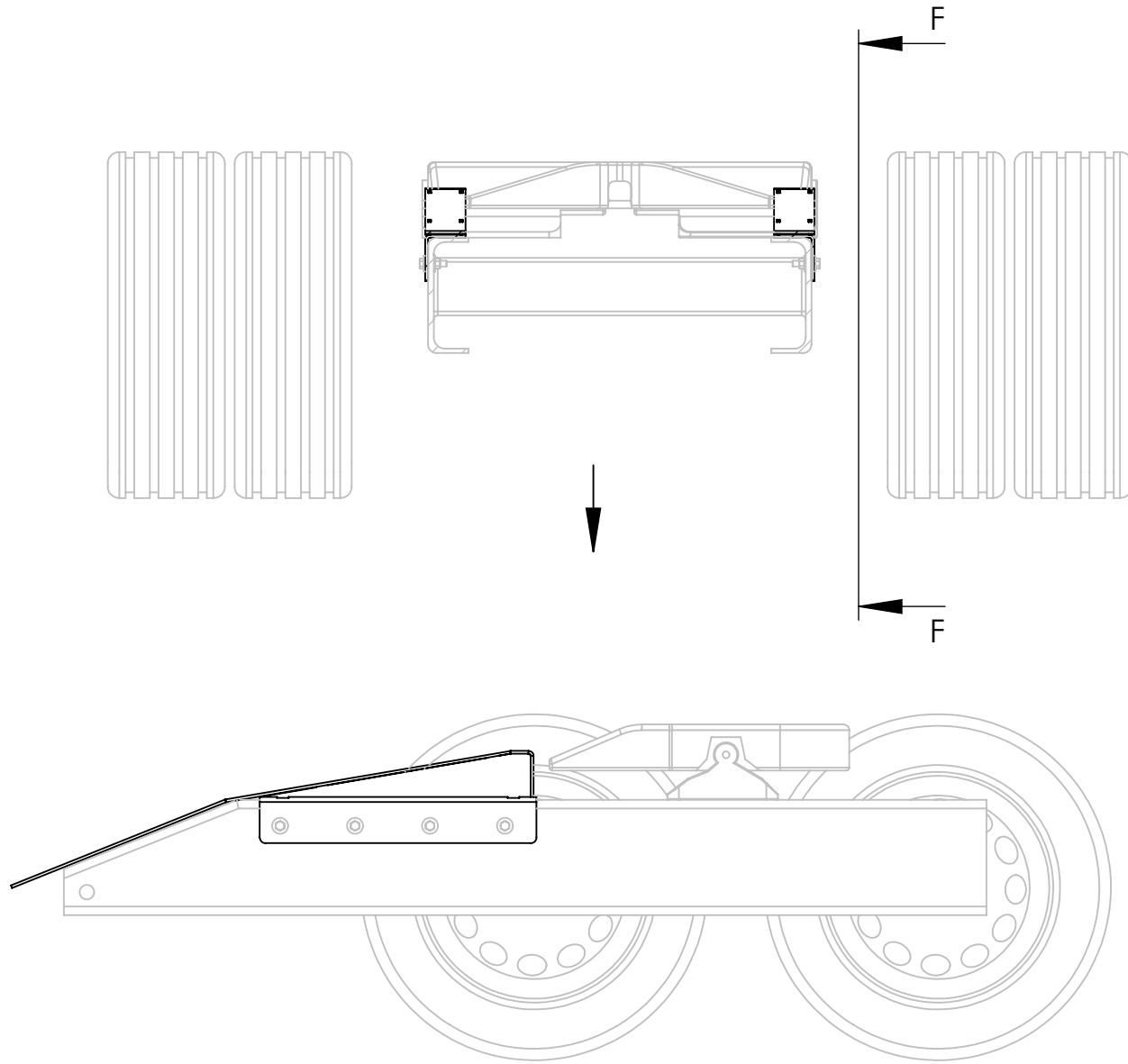

SECTION F-F

Part No.:

1951

MATERIAL: 44W

Approx. Weight: 30.69 lbs

Surf. Area: 6.56 sq. ft.

THICKNESS: 0.250

ICONIC ELEMENTS

PROPRIETARY AND CONFIDENTIAL
NO PART OF THIS DOCUMENT MAY BE REPRODUCED, STORED IN A RETRIEVAL SYSTEM, OR TRANSMITTED IN ANY FORM, WITHOUT THE WRITTEN PERMISSION OF Iconic Elements Inc.

FINISH: HRAP

TITLE:

4" 5th Wheel Ramp

DWG. NO.: 0845-4-00-G

REV: SHEET:

G 2 OF 2

5

4

3

2

1

D

C

B

A