

SECTION B-B

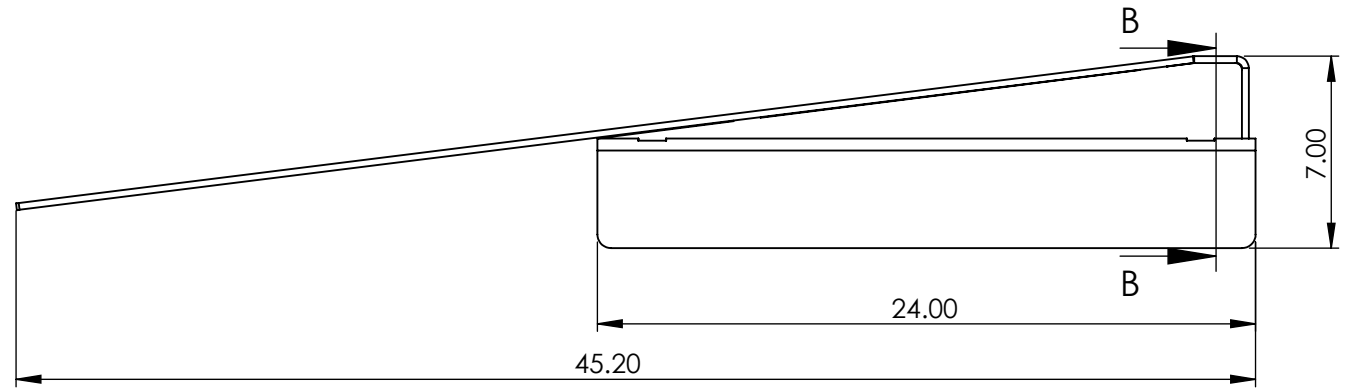

"ALL MATERIAL IS 1/4" THICK, AND IS BOX DESIGNED FOR STRENGTH"

TRIM EXCESS

HEAT AND BEND TO MATCH FRAME ANGLE

DRILL AND BOLT TO MATCH NEW OR EXISTING HOLES IN FRAME

DRILL FOR (4) 1/2" BOLTS MINIMUM

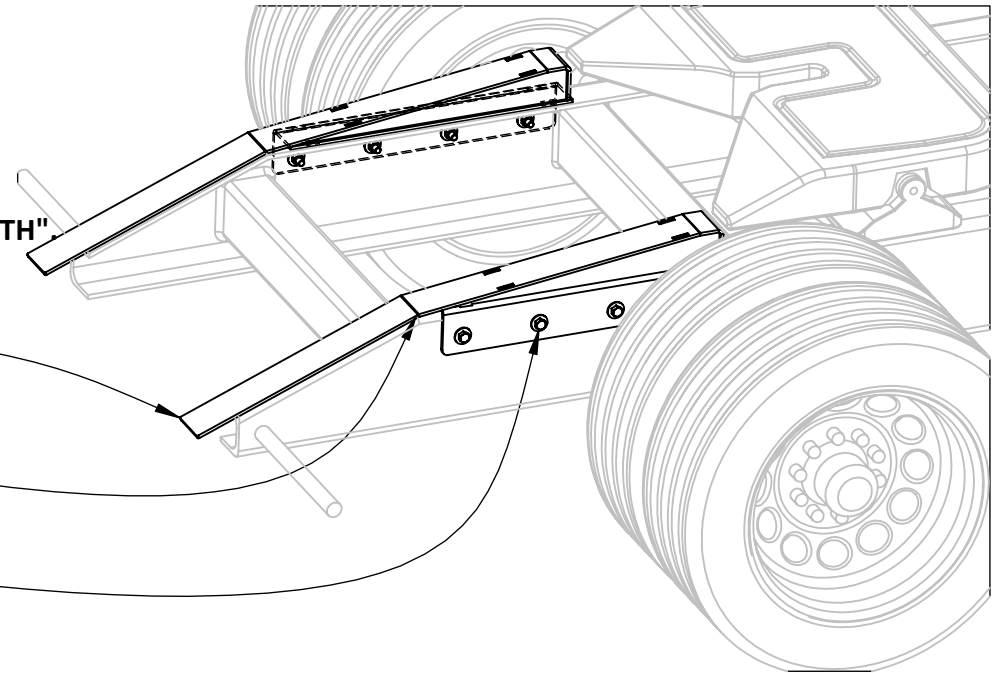

****SOLD IN SETS: 1 LEFT SIDE & 1 RIGHT SIDE****

Part No.:

1950

MATERIAL: 44W

Approx. Weight: 28.66 lbs

Surf. Area: 6.16 sq. ft.

THICKNESS: 0.250

ICONIC ELEMENTS

PROPRIETARY AND CONFIDENTIAL
NO PART OF THIS DOCUMENT MAY BE REPRODUCED, STORED IN A RETRIEVAL SYSTEM, OR TRANSMITTED IN ANY FORM, WITHOUT THE WRITTEN PERMISSION OF Iconic Elements Inc.

FINISH: HRAP

TITLE:

3" 5th Wheel Ramp

DWG. NO.: 0845-3-00-G

REV: SHEET:

G 1 OF 2

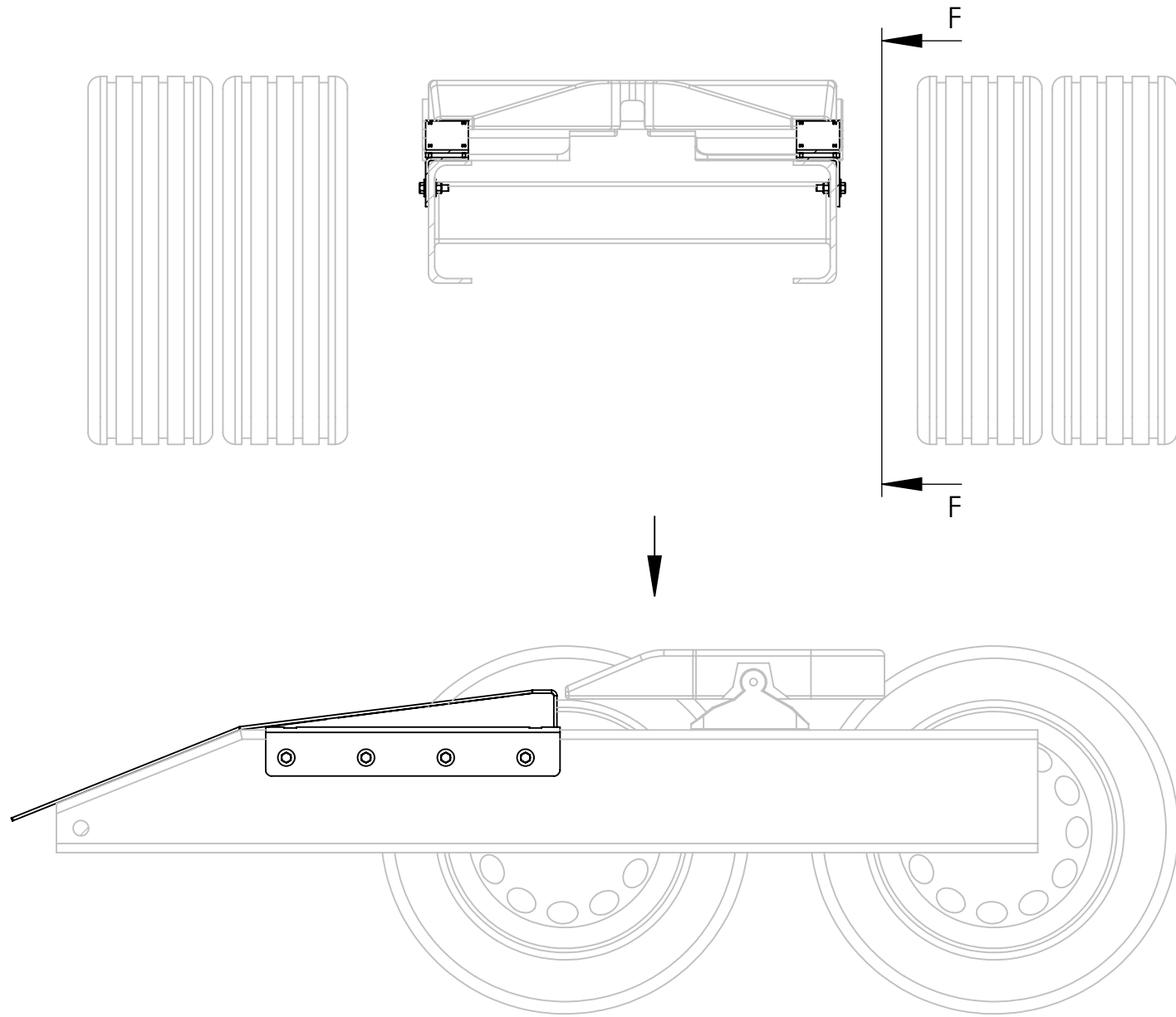

SECTION F-F

Part No.: 1950	MATERIAL: 44W	THICKNESS: 0.250	FINISH: HRAP	DWG. NO.: 0845-3-00-G
	Approx. Weight: 28.66 lbs	ICONIC ELEMENTS		REV: SHEET:
	Surf. Area: 6.16 sq. ft.	<small>PROPRIETARY AND CONFIDENTIAL NO PART OF THIS DOCUMENT MAY BE REPRODUCED, STORED IN A RETRIEVAL SYSTEM, OR TRANSMITTED IN ANY FORM, WITHOUT THE WRITTEN PERMISSION OF Iconic Elements Inc.</small>		G 2 OF 2

TITLE: 3" 5th Wheel Ramp

5

4

3

2

1

D

C

B

A