

REVISIONS			
REV.	DESCRIPTION	DATE	REV BY
A	Preliminary	1/04/2016	HL
B	Changed to formed angle for battery tray and front lip, extended angle full height, shortened shelf depth, added holes/grommets.	2/29/2016	HL
C	Added mounting angles.	6/29/2016	HL
D	Added (1) oval hole to the lid and body.	6/28/2017	RM

****CHECKER FRONT****

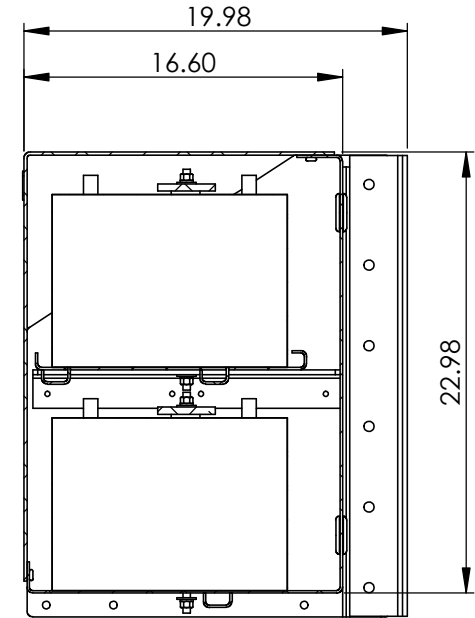
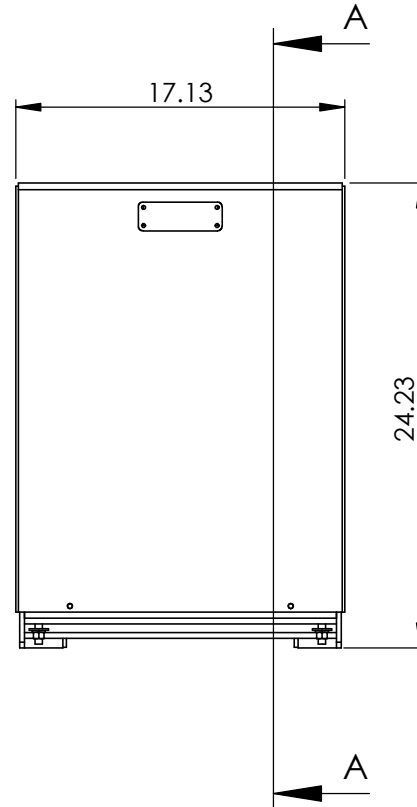
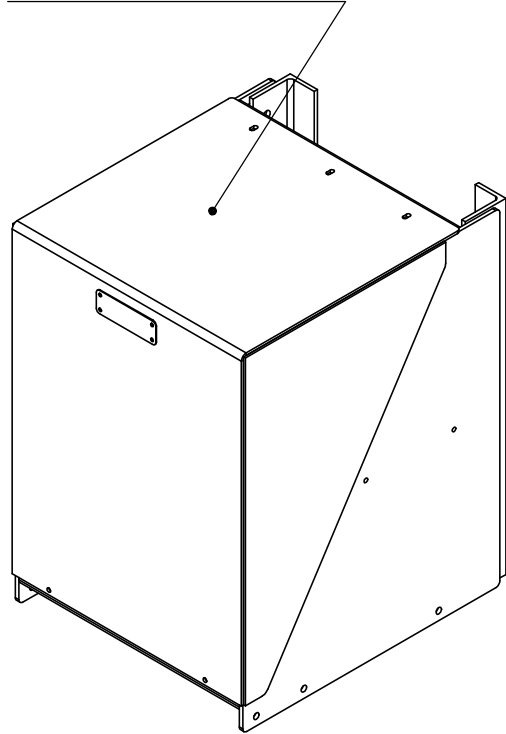

SECTION A-A

Part No.:

1810

MATERIAL: 5052 (Alum)

Approx. Weight: 68.58 lbs

Surf. Area: 79.45 sq. ft.

THICKNESS: 0.125

ICONIC ELEMENTS

PROPRIETARY AND CONFIDENTIAL
NO PART OF THIS DOCUMENT MAY BE REPRODUCED, STORED IN A RETRIEVAL SYSTEM, OR TRANSMITTED IN ANY FORM, WITHOUT THE WRITTEN PERMISSION OF Iconic Elements Inc.

FINISH: Smooth

TITLE:

Battery No-Step Box

DWG. NO.: 1584-0-00-D

REV: SHEET:

D 1 OF 1

5

4

3

2

1